

USER GUIDE

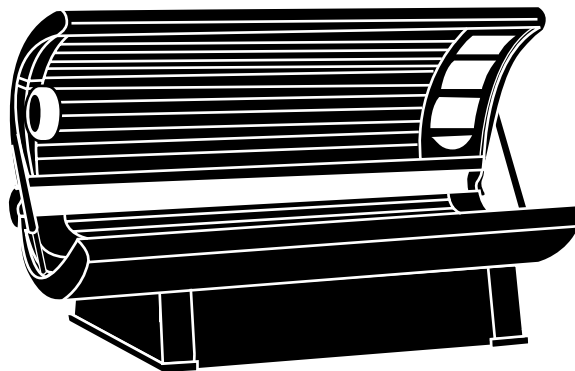

M O D E L S S U P E R Z X 4 0 / 4 0 3 F

Lifetime Warranty



What Is Covered?

SunStar warrants your tanning unit to be free of structural defects in its material and workmanship, under normal use, for its lifetime. *SunStar* will repair or replace, at their discretion, any defect to the structure which affects the performance of the unit.

For 6 months from the date of purchase, *SunStar* will provide replacements for parts that prove to be defective in material or workmanship. Acrylic shields, fluorescent lamps, and lamp starters are excluded from this warranty. Labor will be covered for 30 days from purchase date. Normal wear, damage from misuse or abuse, damage incurred in transit, or damage done by unauthorized repairs or modifications are not covered by this warranty.

How to Obtain Service

All warranty service must be performed by an authorized service person. If your tanning unit must be returned for service, all freight charges must be at your expense. Contact your place of purchase for the address of the *SunStar* Service Center nearest you. Proof of purchase is required to obtain warranty service.

Other Provisions

This warranty covers the original purchaser only. This warranty is void if the unit is modified in any manner from its original design.

This warranty gives you specific legal rights, and you may also have other rights which may vary from state to state.

Welcome



Congratulations on your purchase of this technologically advanced sun tanning unit. It has been designed to provide years of dependable service for you.

Please read all the instructions in this booklet before installing and using the unit. Always be sure to observe all safety precautions.

Contents



Safety Information	<i>iii</i>
Installation	1
Unpacking and Inspection	1
Tools Required	2
Pre-Installation Planning	3
Assembly Hardware	4
Attaching Canopy to Bench Assembly	5
Attaching Gas Springs	7
Electrical Connection	8
Body Fan Assembly	11
Bypass Plug	12
Remote Connections	13
Operation	15
Before You Tan	15
Exposure Times	15
Using Your Sunbed	16
Care and Maintenance	18
Cleaning After Use	18
Thorough Periodic Cleaning	18
Mechanical Inspection	18
Replacing Lamps	19
Troubleshooting	22
Obtaining Service	25

Safety Information



LABELING NOTICE: Labels are affixed on all systems to inform the user of possible dangers. Regulations are stated in 21 CFR, Section 1040.20, and require that all products manufactured after September 8, 1986 which use sunlamps must display the following:

DANGER Ultraviolet radiation. Follow instructions. Avoid overexposure. As with natural sunlight, over-exposure can cause eye and skin injury and allergic reactions. Repeated exposure may cause premature aging of the skin and skin cancer. WEAR PROTECTIVE EYEWEAR; FAILURE TO MAY RESULT IN SEVERE BURNS OR LONGTERM INJURY TO THE EYES.

Medications or cosmetics may increase your sensitivity to the ultra-violet radiation. Consult physician before using sunlamp if you are using medications or have a history of skin problems or believe yourself especially sensitive to sunlight. If you do not tan in the sun, you are unlikely to tan from the use of this product.

Minimum use distance from face tanner (if equipped) is 1 inch or 2.54 centimeters. Minimum use distance elsewhere is touching the clear plastic panels. Do not use without clear plastic panels (or wire grid for models using wire grid) in place. Tanning normally appears after the first few sessions and maximizes after approximately four weeks. Tan once or twice per week thereafter to maintain appearance. Frequency of sessions should be limited to every other day. Persons already having a base tan may begin at advanced levels corresponding to the extent of their base tan.

RECOMMENDED EXPOSURE TIMES IN MINUTES		MAXIMUM EXPOSURE TIME IS 15 MINUTES				
Skin Type:	Week # Session #	Week 1 1st-3rd	Week 2 4th-6th	Week 3 7th-10th	Week 4 11th-13th	Subsequent Maximum
I Sensitive Skin (Burns easily and severely and does not tan.)		NOT RECOMMENDED FOR TANNING				
II Light (Burns easily and severely and tans minimally.)		3	6	9	12	15
III Normal (Burns moderately and tans average.)		4	7	11	15	15
IV Dark (Burns minimally, tans easily and above average.)		5	9	13	15	15

New lamps emit approximately 20% more UV during the first 50 hours of operation. Recommended tanning times should therefore be reduced by approximately 20% during that period.

WARNING: • Read the instructions booklet before using this sunlamp product. • To use, lie down under canopy and pull down as far as adjustment will allow. All persons in the room should wear protective eyewear when lamps are on. • Recommended eyewear: provided eyeshields (Lucas Products Super Sunnies or Intrexco No. 5635/1) or equivalent eyewear as defined under 21 CFR 1040.20. Other types of eyewear may not provide adequate protection. • Disconnect power cord before attempting to clean, relamp, or engage in the maintenance of this product.

ONLY THE FOLLOWING LAMPS HAVE BEEN CERTIFIED FOR USE IN THE MODEL SUPER ZX40:

Velocity Wolff Model 71T12100W

ONLY THE FOLLOWING LAMPS HAVE BEEN CERTIFIED FOR USE IN THE MODEL SUPER ZX44-3F:

Velocity Wolff Model 71T12100W

Phillips Model HPA 400/30s or CosmoTech Model 23045 or CosmoTech 20046 (Facial Unit)

THIS EQUIPMENT MUST BE CONNECTED TO A GROUNDED OUTLET.
THIS PRODUCT IS IN CONFORMITY WITH PERFORMANCE STANDARDS FOR SUN LAMP PRODUCTS UNDER 21 CFR PART 1040.20

Installation



Unpacking and Inspection

Your sunbed comes in two cardboard cartons, one for the bench and one for the canopy or top deck. Open the cartons and remove the bench and canopy as follows.

The bench and canopy are each wrapped in plastic. With a helper, grasp the canopy and pull it from the carton bottom, leaving the plastic wrap and the carton packaging. Next, remove the bench from its box by lifting it directly up and out of the box, clearing the ballast trays located below. Remove the ballast trays from the pallet by removing the screws from the tray tie-down straps.

Note! The cartons are reusable, in the unlikely event that you may find it necessary to return your sunbed.

The canopy box contains the canopy unit, a pair of gas springs, and the body fans. The bench box contains the following items:

- Bench Unit
- Box containing necessary assembly hardware, remote bypass, safety goggles, and pillow
- Box containing the front access panel and panel key.

Inspect these items, including the canopy and bench, and make sure they are free from any visible damage.

Record the serial numbers of the canopy and bench in the area provided on the back page of this manual. This information will be required whenever you call customer service.



Tools Required

You'll need the following tools to assemble your sunbed:

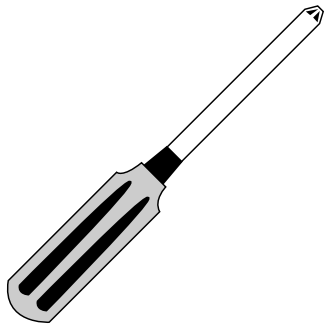

#2 Phillips Screwdriver

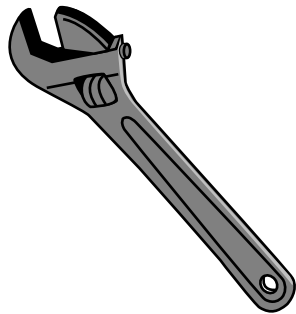

Adjustable Wrench



Pre-Installation Planning

Before you begin to assemble your sunbed, you should observe the following pre-installation considerations.

- Your sunbed operates from a 220V AC source. The unit must be wired to a dedicated circuit as described below.
(We recommend connection by a professional electrician.)
- **IMPORTANT!** Voltage must be below 230V AC or may require a Buck Booster, contact ETS service at the number at the back of this guide. Use of a voltage source above 230 VAC may reduce the life of some components in your sunbed.
- **The SunStar ZX40** require a dedicated circuit capable of providing **40 Amp** service. This unit must be hardwired directly to a junction box.
- **The SunStar ZX40 3F** requires a dedicated circuit capable of providing **40 Amp** service. This unit must be hardwired directly to a junction box.
- Make sure the room in which you intend to use your sunbed is well ventilated. Air from the room is used to cool the sunbed, and a poorly ventilated room may cause the unit to become hot and cause discomfort to the user.
- Your sunbed is designed to operate in an ambient room temperature of 80°F maximum and 70% relative humidity.
- Place your sunbed no closer than 6" from any wall. Make sure that curtains, drapes, and other room furniture do not obstruct the airflow into the end caps or out of the fan opening areas.
- Proper assembly of your sunbed requires three people. Plan to have a couple of helpers assist you.



Assembly Hardware

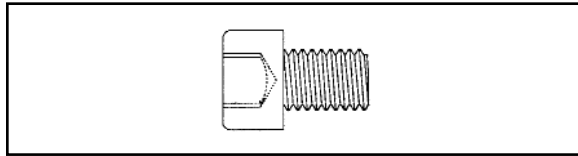

BOLT M8X12

2X

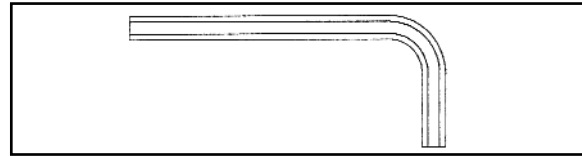

HEX KEY

1X

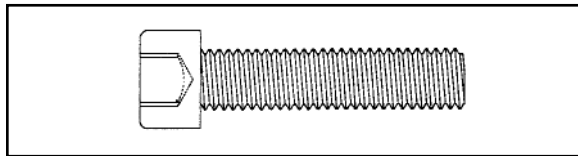

BOLT M8X35

4X

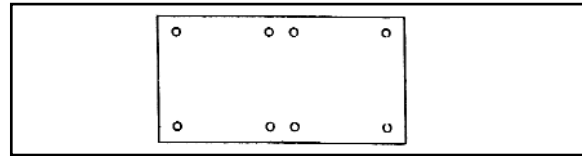

TRAY CONNECT BRACKET

2X

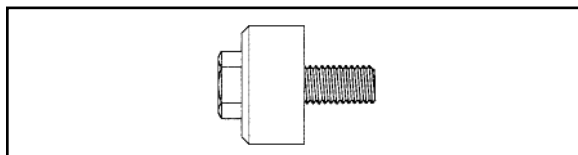

PIVOT STUD SUPPORT

2X

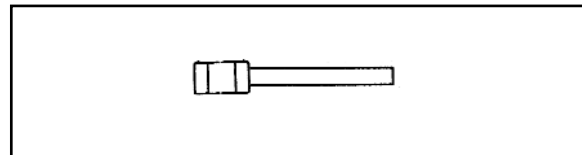

CABLE TIE

2X

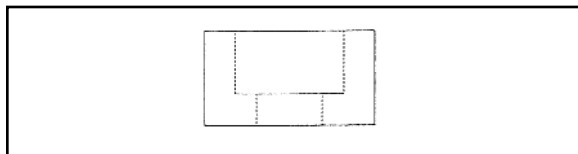

RING

2X

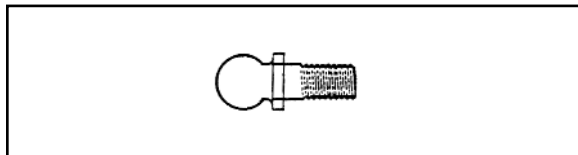

PIN-BALL

4X

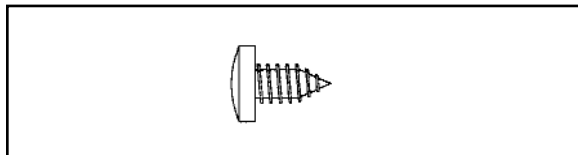

SCREW #8X3/8"

16X

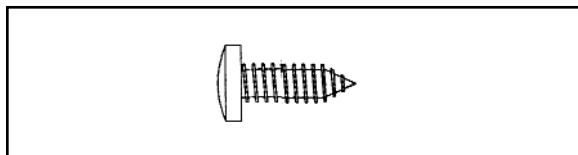

SCREW #10X1"

3X



Attaching Canopy to Bench Assembly

- Step 1.** Place the sunbed bench where you want the completed bed to be located. The bed will be difficult to move once fully assembled.
- Step 2.** Attach the support bracket (A) to the back end of the bench (C) with the M8x35 bolt (B).

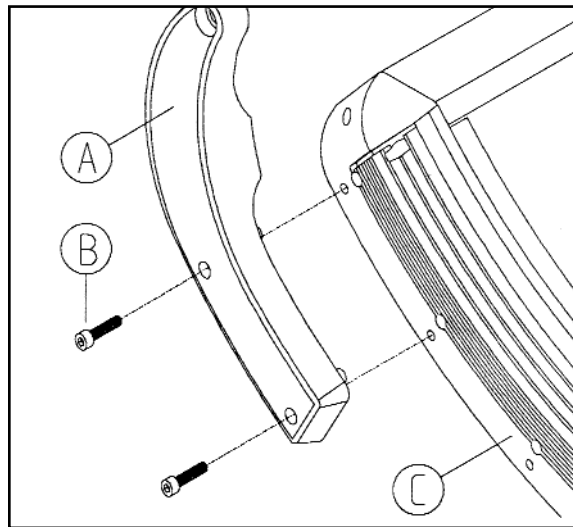

- Step 3.** Attach the pivot studs (A) on both sides of the canopy (B) using the adjustable wrench, tighten firmly.

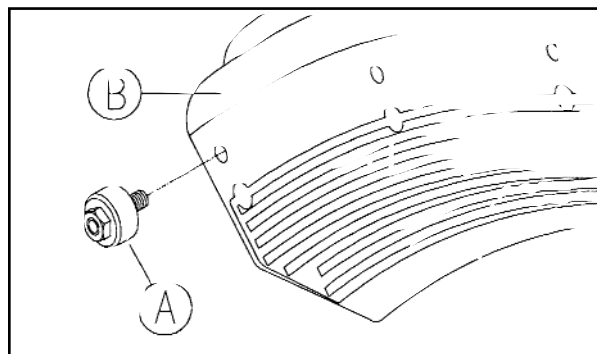



- Step 4.** With the help of two other people, lift the canopy and position it between the support brackets. Now finish tightening the support bracket. Secure the entire assembly with the rings (A) and the M8x12 bolts (B).

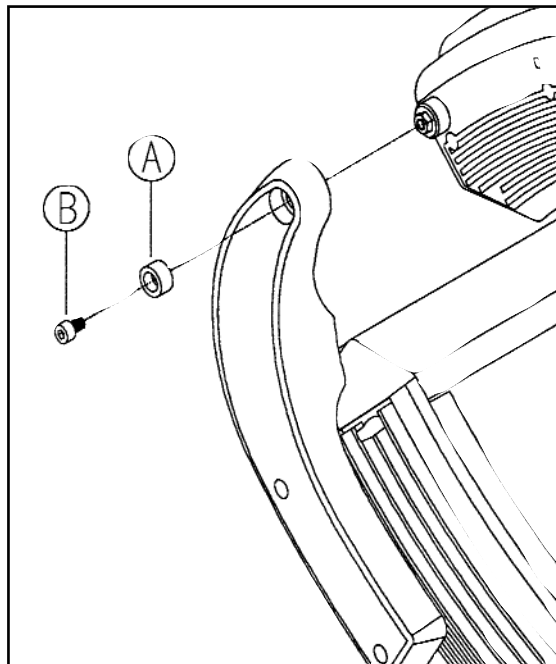



Attaching Gas Springs

Step 1. Using the adjustable wrench insert the pin-ball (C) into the end caps. Repeat for the other side. Tighten firmly.

Step 2. Remove the locking clips (E) from the ends of the gas springs.

Warning! Have a helper hold the canopy until the gas springs and their locking clips are installed.

Step 3. Connect the gas springs socket ends (D) to the pin-balls. Make sure the gas spring (F) is mounted with its extending rod end at the bottom. Replace the locking clips.

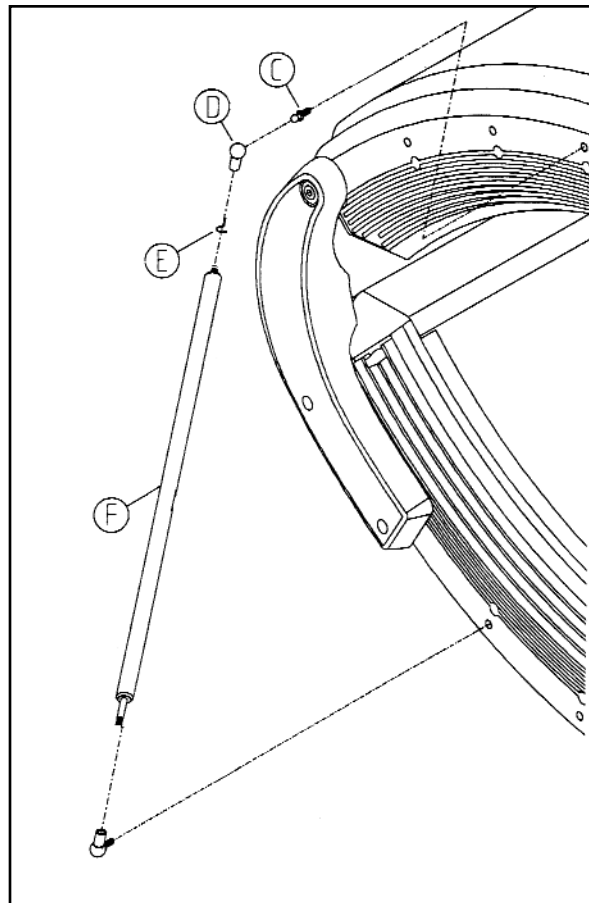



Electrical Connections

1. Remove the benches back plate (B) by removing its four screws (C).
2. Slide the gray flexible tubing leading from the canopy in slot (A) about 1 inch.

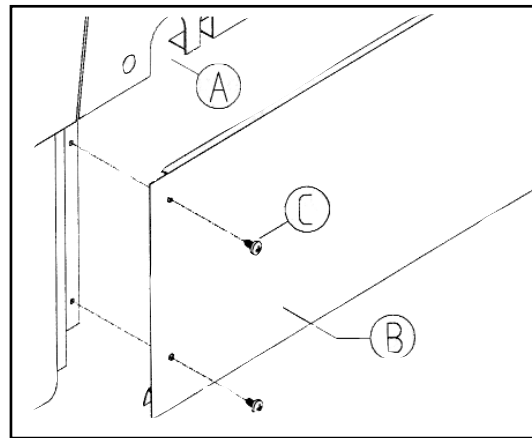

3. Run all the wires coming out of the tube except for the shielded low voltage cable through the front and back cable holders located on the inside of the head end of the stand.
4. Place the ballast trays in front of the unit. The ballast trays are shipped in the correct positions under the sunbed bench.
Note: If these positions were not noted during unpacking:
The foot end tray is the one that has the power cord coiled up on it.
Both trays have lamp ballasts mounted in the back section of the tray.
5. Route the main power cable and all the wires coming out of the bench through the front cable holder located on the inside of the foot end of the bench. Continue to route the power cable through the back cable holder and then through the strain relief insert located on the back panel.
6. Fasten the two ballast trays together with the #8x3/8 screws, and the tray connect brackets. Do this at the front and back of the trays.
7. Electrically connect the trays together by connecting the 13 pin (40 3F) or 9 pin (40) connectors from each tray.



8. Slide the tray set partly under the bench.
9. Mate the three cables assemblies coming from the bench to the matching connectors on the foot end ballast tray.
10. Mate the three cables coming from the canopy to the matching connectors on the head end ballast tray.
11. Route the shielded 7 pin low voltage cable from the canopy as shown.

Note: This cable transmits digital communication between the main timer display located in the canopy. It is important to route the cable as shown below to minimize the possibility of effecting the communication.

12. Use a cable tie to secure the cable connector to the main timer box.

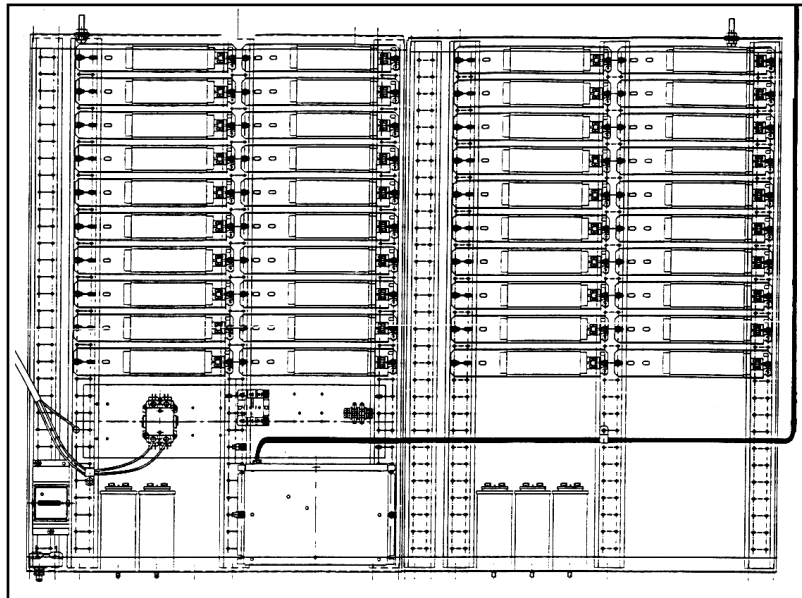

13. Route the 4 pin shielded low voltage cable which has one end already connect- ed to the main timer box, to the phone jack type connector on the bench back panel. Secure this connection with a cable tie.



14. Push the ballast tray set all the way under the bed and attach the front access panel using the key provided.

Note: The access panel must depress the limit switch located on the front of the ballast tray. If it does not, an error 9 will be displayed on the timer display when the unit is powered-up. Adjust the positioning pins on the back of the ballast trays if needed to achieve proper limit switch travel.

15. Replace the back panel with the four screws removed earlier.

16. Attach handle to canopy, using the #10x1" screws, into the predrilled holes on the front of the canopy.

17. Have an electrician hardwire the power cable directly to a dedicated circuit. See *Pre-Installation Planning*.

18. Your sunbed is now ready for use.



Body Fan Assembly

! WARNING!

Make sure sunbed unit is not connected to any power source before attaching body fans.

1. Remove the pre-installed cap, mounting bolt and washers from the foot end of the sunbed canopy.
2. Orient the body fan to the endcap so that the body fan bracket angles toward the inside of the bed. Mount the body fan using the removed hardware.
3. Replace the plastic cap.
4. Verify that the metal stud on the bracket is inserted into the hole in the endcap beneath the mounting hole.
5. Plug the cord from the body fan into the connector from the bed.



Bypass Plug

Connect the remote Control Bypass to the Remote Control port. The bypass plug can be inserted into either port. Your sunbed will not operate without the bypass plug or a remote system connected. If you plan on using a remote system refer to “Remote Connections”.

Note: The remote control device is optional and is not included with your sunbed.

Caution: Remove the bypass plug when using a remote system except for the sunbed at the end of a **ComputaTAN™** or **T-Max Manager** series.





Remote Connections

Your sunbed incorporates advanced circuitry allowing it to connect and communicate with most remote control systems. If a remote system is to be used, the type of system you are using must first be determined.

Warning: The remote connection is not designed to supply or accept high voltage, nor can it provide power to an external timer. Only use remote systems that incorporate an isolated contact or relay. Failure to do so will void your warranty and may damage the sunbed.

Caution: Remove the bypass plug when using a remote system except for the sunbed at the end of a **ComputaTAN™** or **T-Max Manager** series.

ComputaTAN™ or T-Max Manager Remote Systems

The ComputaTAN and T-Max Manager remote systems offer the ultimate in sunbed control, while allowing the tanner easy straightforward operation. Your sunbed is already configured to directly connect to these systems. To connect your bed to either of these systems follow the instructions that came with your remote system, noting the hints listed below. If you still have questions call ETS at the phone number listed at the back of this guide.

Setting the address Before connecting your sunbed to either the ComputaTAN or T-Max Manager series, the address or “id” of your sunbed must first be set. Each sunbed connected to the series must have a different “id” number. To set the address,

1. Verify that the sunbed display is indicating a “0”.
2. Press and hold the stop button located on the sunbed display for three seconds and release. The display should indicate an “id” number from 1 to 99.
3. Set the “id” to a unique number by pressing the timer button until the desired number is achieved. Holding in the timer button will increase the “id” scroll rate.
4. Press the stop button to return to the normal display mode.

Note: If you are having trouble getting into the “id” mode, it is probably because you have already attempted to connect your sunbed to the remote system. Disconnect the remote plug(s) from the ports at the back of the sunbed, wait 90 seconds and try again.

T-Max Manager The T-Max 1A is not needed when connecting your sunbed to the T-Max Manager series. The circuitry inside your sunbed eliminates the need for the T-Max 1A. Simply connect the RJ-22 Modular cable(s) described in the T-Max Manager manual directly into the port(s) located on the back of your sunbed. You can place your sunbed at any location in the series. Remember the last connection in the series requires a terminator plug.



Note: The by-pass plug provided with your sunbed will work wherever a T-Max terminator is called for in the series. The terminator provided by T-Max will not work as a bypass plug. A bypass plug is needed only when your sunbed is operated without a remote system connected.

Remote systems using a Control Relay

Most modern remote systems control the sunbed by the use of a relay. The relay operates the sunbed by connecting and disconnecting a pair of wires leading from the sunbed. Refer to the user's manual provided with your remote system to determine if it operates in this way. To connect your sunbed to this type of system a remote interface kit is required. Call ETS at the phone number listed at the back of this guide to obtain the kit. Follow the instructions provided with the kit and from the remote's manual to make the necessary connections.

Caution: Remove the bypass plug when using this type of remote system.

Operation



Before You Tan

Before using your sunbed, please note the following important precautions:

- **WARNING!** Your sunbed is designed for individual use. Only one pair of protective goggles is provided. **Always** wear these or another approved pair of goggles. Regular sunglasses **do not** provide adequate protection from ultra-violet light. You should never look at the lamps when turned on without wearing the appropriate protective goggles.
- Your skin should be free of cosmetics, tanning oils, or other body lotions prior to tanning except for those specifically made for use with tanning devices. However, do not remove natural body oils by bathing or showering immediately before tanning.
- Your hair should be free of gels, mousses, sprays, or other hair products prior to tanning. These products can cause damage to the sunbed acrylic. As an alternative, a shower cap or towel can be worn to keep treated hair away from the sunbed surfaces.
- Some medication may **increase your sensitivity** to ultraviolet light. It is recommended that you consult a physician before using this sunbed if taking any medication or if you suspect that your skin might be especially sensitive to sunlight. Included with this manual is an FDA booklet on medications that increase sensitivity to light.
- As with all electrical appliances, **do not operate this device near water or while you are wet.**

Exposure Times

We recommend that you tan every other day, following the tanning times in the exposure schedule. Tanning normally appears after the first few sessions and maximizes after approximately four weeks. Tan once or twice per week thereafter to maintain appearance. Persons already having a base tan may begin at advanced levels corresponding to the extent of their base tan.

Follow the guidelines for skin type and exposure times as shown in the table below.

RECOMMENDED EXPOSURE TIMES IN MINUTES		MAXIMUM EXPOSURE TIME IS 15 MINUTES				
Skin Type:	Week #	Week 1	Week 2	Week 3	Week 4	Subsequent
	Session #	1st-3rd	4th-6th	7th-10th	11th-13th	Maximum
I Sensitive Skin (Burns easily and severely and does not tan.)	NOT RECOMMENDED FOR TANNING					
II Light (Burns easily and severely and tans minimally.)		3	6	9	12	15
III Normal (Burns moderately and tans average.)		4	7	11	15	15
IV Dark (Burns minimally, tans easily and above average.)		5	9	13	15	15



Using Your Sunbed

When configured as a stand alone unit or when connected to a remote system using a control relay.

If your sunbed is connected to a ComputaTAN™ or T-Max Manager remote system, turn to *Using Your Sunbed When connected to the ComputaTAN or T-Max Manager.*

Step 1. Lift the canopy, lie down in the bench (face up), and lower the canopy toward your body using the canopy handle. For best results, position the canopy as close as possible to your body. For units with face tanners maintain at least 1 inch between the face tanner and your face.

Step 2. Start the sunbed by pressing the timer button (G), located at the head end of the canopy. The lamps will turn on and the timer display (E) will indicate the session time remaining. **Note:** If the lamps do not come on then either the remote bypass plug is not installed, see *Electrical Connections* or an external timer is being used that has not yet been activated. The timer will not begin to count down until the remote system activates.

Step 3. If less than the maximum tanning time is desired, repeatedly press the timer button until the desired time is indicated.

Step 4. On units with face tanner lamps, the main lamps and face tanner lamps can be individually controlled. Press the face tanner button (A) to turn on and off the face tanner(s). Press the main lamp button (B) to turn on and off the body lamps.

Step 5. Control the body fan speed by pressing button (C). View indicator (D) to determine the body fan speed. When the bar is fully lit the speed is high, two-thirds lit is medium, one third lit is low, and nothing lit is off.

Step 6. When the timer reaches 0, the lamps will turn off. If you want to stop your session before time expires press the stop button (F). The sunbed will then allow you ten seconds to reactivate the bed with the unused time. After ten seconds the timer system resets back to 0 minutes.

Step 7. Raise the canopy by using the handle, try not to push-up on the acrylic shield. The cooling fans run for 3 minutes after the lamps shut off to aid in cooling the sunbed.

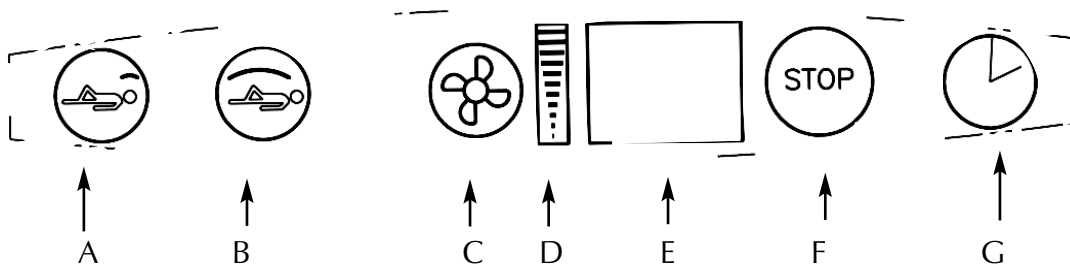



Using Your Sunbed

When connected to the ComputaTAN™ or T-Max Manager

Step 1. Lift the canopy, lie down in the bench (face up), and lower the canopy toward your body using the canopy handle. For best results, position the canopy as close as possible to your body. For units with face tanners, maintain at least 1 inch between the face tanner and your face.

Step 2. Observe the timer display. Assuming the remote system has been set to allow a pre-tanning delay time, the display will repeatedly flash the delay symbol “dL” and then the remaining delay time. Either press the timer button (A) or wait until the delay time has expired to begin the tanning session. The display will now indicate the tanning time set by the remote system, the lamps will turn on and the timer will begin to count down. The sunbed will not allow a session time greater than the sunbeds maximum exposure time.

If the timer did not display a “dL” but does indicate

a “0” then either the remote device has not yet been set, or the sunbed has not been connected to the remote system, see *Remote Connections*.

a tanning time and the lamps have come on, then either a delay time was not set or the delay time has already expired and the tanning session has begun.

a tanning time and the lamps have not come on, then the auto start function of the external remote system has been turned off. Press the timer button to turn on the lamps.

Step 3. If a tanning time less than the displayed time is desired repeatedly press the timer button to decrease the remaining time.

Step 4. On units with face tanner lamps, the main lamps and face tanner lamps can be individually controlled. Press the face tanner button (A) to turn on and off the face tanner(s). Press the main lamp button (B) to turn on and off the body lamps.

Step 5. Control the body fan speed by pressing button (C). View indicator (D) to determine the body fan speed. When the bar is fully lit the speed is high, two-thirds lit is medium, one third lit is low, and nothing lit is off.

Step 6. When the timer goes below 1 minute it will begin to count in seconds until it reaches 0, then the lamps turn off. If you want to stop your session before time expires press the stop button (F). The sunbed will then allow you ten seconds to reactivate the bed with the unused time. After ten seconds the timer system resets and cannot be reactivated from the sunbed.

Step 7. Raise the canopy by using the handle, try not to push-up on the acrylic shield. The cooling fans run for 3 minutes after the lamps shut off to aid in cooling the sunbed. The timer will then indicate “. . .”, this is a reminder to clean the sunbed. After the sunbed is cleaned press the start button to clear the clean bed indication. The display will then return to “0”.

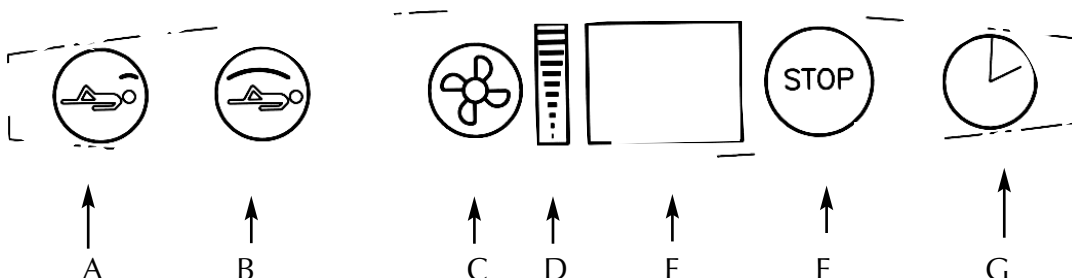

Care & Maintenance

Cleaning After Use

Clean and disinfect your tanning bed's bench and canopy after each use. Use a non-abrasive disinfectant cleaner that **does not contain ammonia or ammonia derivatives**.

Ammonia may damage the acrylic shield. Spray the acrylic lightly with disinfectant and wipe dry with a clean soft cloth. We recommend *SunQuest* disinfectant and *SunQuest* acrylic cleaner.

Thorough Periodic Cleaning

Introduction

The cooling fans draw air through the bed and over time will cause a dust buildup in the sunbeds air filters. Clean these filters monthly. The filters are located on the bottom of both ends of the bench and on the canopy underneath the top covers. They are held in place by velcro strips. Clean the filters using a vacuum or with mild soap and water.

Occasionally, dust will pass by the filters causing a dust build up on your sunbeds lamps and reflectors. This will reduce the tanning effectiveness of the bed. When a dust buildup is observed, it is necessary to thoroughly clean the inside of the bench and canopy.

Warning! Disconnect sunbed from electrical power before cleaning.

Cleaning the Canopy and Bench

- Step 1.** Remove the acrylic shields and lamps as described in *Replacing Lamps*.
- Step 2.** With a soft cloth, wipe the entire length of each lamp to remove any film build-up.
- Step 3.** Clean both sides of the acrylic shields with a non-ammonia disinfectant cleaner.
- Step 4.** Wipe the reflectors with a clean damp cloth.
- Step 5.** Re-install the lamps and acrylic shields.

Mechanical Inspection

Your tanning bed has been built for years of service. To ensure trouble free operation throughout its life, inspect the unit's mechanical integrity every 400-500 hours of use.

- Inspect the unit's fasteners verifying that all are firmly in place.
- Inspect gas springs for signs of wear. Gas springs that will not steadily hold up the canopy should be immediately replaced See *Troubleshooting*.
- Inspect the AC power cable and its connections.
- Inspect the acrylic. Broken, cracked or badly scratched acrylics should be immediately replaced.



Replacing Lamps

Introduction

Your suntan bed has an hour meter located in the foot end of the ballast tray which keeps track of how many hours the sunbed has been in operation. Use this meter to determine when your tanning lamps should be replaced. To be assured of maximum tanning effectiveness, change the lamps after approximately 800-1000 hours of use. Tanning will continue after this time but at a slower rate. To ensure trouble-free operation of your sunbed, replace the lamp starters whenever the lamps are replaced.

Warning! Disconnect sunbed from electrical power before servicing.

Removing/Replacing Acrylic Shields

- Step 1.** The acrylic shields in the canopy and bench are both secured in place by acrylic covers which run the length of the canopy and bench, both front and back. To remove the acrylic shield gently pry up on acrylic side of the cover, working your way along the full length of the acrylic shield until the cover is released. Repeat for the other cover. The edges of the acrylic are now exposed.
- Step 2.** Remove the sprung steel acrylic center shims from both ends of the acrylic, front and back.
- Step 3.** Slide the acrylic shield toward the head or foot end of the bed. The short edge of the acrylic shield at the opposite end will now be visible. Remove the shield by lifting from this end.
- Step 4.** Replace the acrylic shield by reversing the above steps.



Removing/Replacing Lamps

After removing the acrylic shield, replace lamps as follows:

- Step 1.** Grasp the lamp at one end and at the middle, then turn the lamp a quarter turn. The lamp may then be gently removed from its holder.
- Step 2.** To re-install a lamp, insert the pins located on the ends of the lamp into the slots on top of the lamp holder and turn the lamp a quarter turn.

Recommended Replacement Lamps

We recommend using the lamps specified below. Use of uncertified lamps is a violation of federal regulations and will void your warranty. These lamps have an average life of 800-1000 hours of effective tanning use. Lamps used longer than that begin to lose their effectiveness even though they will continue to light.

Only the following lamp types have been certified for use in your SunStar Solarium

**SUPER
40**

Application	Lamp Model Number
Canopy and Bench	Velocity Wolff Model 71T12100W

Only the following lamp types have been certified for use in your SunStar Solarium

**SUPER
40 3F**

Application	Lamp Model Number
Canopy and Bench	Velocity Wolff Model 71T12100W
Facial Unit	Phillips Model HP A 400/30s CosmoTech Model 20045 CosmoTech Model 20046



Removing/Replacing Face Tanner Lamp on F Models

After removing the canopy acrylic shield, replace the face tanner lamp as follows:

- Step 1.** Support the face tanner assembly with your hand while unscrewing the two retaining screws. The face tanner glass casing will now swing downward.
- Step 2.** The lamp can now be exchanged. The lamp holders are equipped with spring contacts which enables the lamp to be removed easily. Remove the old lamp and discard. Install the new lamp, using a clean cloth or paper towel. Ensure that the lamp is firmly seated in the lamp holders.

Note! Never take hold of the lamp such that your fingers are in contact with the lamp glass. Finger oils will greatly reduce the lamp's operational life.

- Step 3.** Gently close the face tanner glass casing and lock it closed with the screws. Ensure that the screws firmly secures the glass casing.

Warning! Never turn the equipment on while the face tanner is disassembled or when the glass filters have been removed. The direct light can cause severe injury to the eyes and to other areas of the body. Immediately discontinue use of this equipment if the face tanner glass is broken or if any unfiltered light can be seen escaping the face tanner assembly.

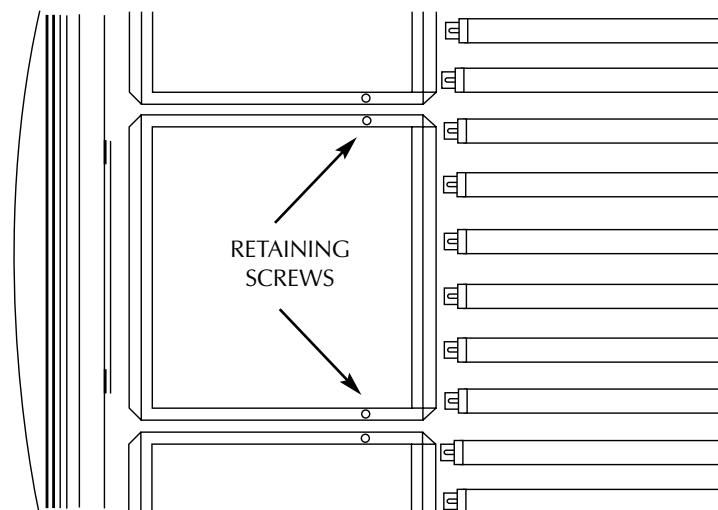

Troubleshooting



Problem/Solution Chart

Problem	Solution
Lamps fail to light and timer display is blank	<ol style="list-style-type: none"> 1. Make sure the unit is connected to a power source. 2. Check source of ac power. Reset circuit breaker or replace fuse.
Timer display continues to show a 0 after the timer button is pressed	<ol style="list-style-type: none"> 1. ComputaTAN or T-Max Manager remote system has not yet been set. 2. Sunbed address is not set correctly see <i>Remote Connections</i>.
Timer display changes to indicate a tanning time after the timer button is pressed but lamps do not come on	<ol style="list-style-type: none"> 1. Bypass plug is not installed see <i>making electrical connections</i>. 2. If remote is being used other than ComputaTAN or T-Max Manager, remote wiring is incorrect, see the instructions provided with the remote interface kit.
My bed is connected to the ComputaTan or T-Max Manager remote system and when the delay time has expired the timer display starts counting down but the bed lights do not come on	The auto start feature of the remote system is disabled, see the instructions provided with your remote system.
My bed won't work with the ComputaTan or Tmax Manager remote systems	<ol style="list-style-type: none"> 1. The sunbed must first be set to a unique address see <i>remote connections</i>. 2. The bypass or terminator plug may be installed in the series in an inappropriate location. Plug in the bypass plug only into the bed at the end of the series.
The last minute of tanning time does not count down from 59 seconds, but some time less than 59 seconds	If the timer button has been pressed to decrease tanning time during the session, the time expired in the current minute is subtracted from the last minute.



Problem/Solution Chart

Problem	Solution
One or more lamps fail to light	1.Check that lamp is installed correctly. 2.Switch unlit lamp with a lamp that lights, if the new lamp lights and the old lamps still does not, replace old lamp.
The face tanners will not come on	1.Face tanner operation is initially delayed by 5 seconds. 2.If face tanners have been shut-off when warm they will not re-light until cooled. 3.Replace face tanner lamp, see <i>removing and replacing Face Tanner Lamp on F Models</i> .
Timer display is indicating Er 1	Body lamps are on when they should be off, have service technician check the contactor (On SunStar 40 and 44 this error is for canopy body lamps only).
Timer display is indicating Er 2	Body lamps are off when they should be on, have service technician check contactor and its wiring from the main timer box (On SunStar 40 and 44 this error is for canopy body lamps only).
Timer display is indicating Er 3	Bench body lamps are on when they should be off, have service technician check the contactor (This error is for SunStar 40 and 44 only).
Timer display is indicating Er 4	Bench body lamps are off when they should be on, have service technician check the contactor and its wiring from the main timer box (This error is for SunStar 40 and 44 only).
Timer display is indicating Er 5	Not currently used
Timer display is indicating Er 6	Not currently used



Problem/Solution Chart

Problem	Solution
Timer display is indicating Er 7	Face Tanner contactor is closed when it should be open, have service technician check the contactor.
Timer display is indicating Er 8	Face Tanner contactor is open when it should be closed, have service technician check the contactor and its wiring from the main timer box.
Timer display is indicating Er 9	Ballast Drawer is open or drawer switch needs adjustment or is broken. (See Step 14 of <i>Electrical Connections</i>)
Timer display is indicating Er 10	Timer computer is in an illegal state, reset power to correct, replace main timer if error reoccurs.
Timer display is indicating Er 11	Timer configuration is corrupt, replace timer.
Timer display is indicating Er 12	Timer configuration is corrupt, replace timer.
Timer display is indicating Er 13	Timer computer is in an illegal state, reset power to correct, replace main timer if error reoccurs.
Timer display is indicating Er 14	The timer display is not responding; <ol style="list-style-type: none"> 1. Check cable to display. 2. Replace display assembly. 3. Replace main timer box.
Timer display is indicating Er 15	Timer configuration is corrupt, replace timer.

Obtaining Service



To arrange for service, or for more information about your sunbed,
contact ETS as follows:

CALL FOR SERVICE OR QUESTIONS:

1 • 800 • 449 • 3605



**6270 Corporate Drive
Indianapolis, IN 46278-2900**

Have the following information ready when calling ETS
to order parts or service for your bed:

Date Purchased _____

Canopy Serial Number _____

Bench Serial Number _____

Manufactured for SunStar by:
Spectrum Products, Inc.
6220 Churchman Bypass
Indianapolis, Indiana 46203





